

# SM-RI-2

Turbine gas meters DN200 - 600  
for custody transfer



## Applications

Gas measurement at high operating pressures

## Brief information

The new generation SM-RI-2 is the first turbine gas meter on the market allowing bi-directional measurement, while the flow capacity has been increased to match the existing ultrasonic gas meter capacities for the same size.

The pressure drop can be half of that of conventional turbine gas meters, therefore the SM-RI-2 is especially dedicated for custody transfer measurement in gas transmission.

Because of its unique bi-directional option the meter is also ideally suited for interconnection pipelines, import and export stations and underground storage applications. This SM-RI-2 is designed to function perfectly together with an ultrasonic gas meter and to reach high redundancy rates. Its optimized design allows consistently high accuracy thanks to reduced sensitivity with regard to fouling.

**Principle:** The gas flow through the meter sets a turbine wheel in motion and the number of revolutions of the wheel is proportional to the passed volume.

The flow passes the patented X4X flow conditioner taking away any potential flow disturbances such as swirl or asymmetric flow.

When the gas passes through the flow conditioner, the flow velocity is increased and, consequently, the driving impulse on the turbine wheel is also increased. This results in a highly accurate measurement within the permissible error limits, even with low flow rates. The shaft of the wheel is mounted on robust ball bearings.

A gear reduces the revolutions of the turbine wheel. Via a magnetic coupling, a transmission shaft drives the 8-digit mechanical roller counter located in the index head. After the gas has passed the turbine wheel, it flows through a specific outlet channel, designed for optimum pressure recovery.

**Conformity:** Elster-Instromet SM-RI-2 meters are manufactured in accordance with DIN EN ISO 9001:2000 (DIN EN ISO 14001). They are designed, produced and tested in accordance with the following guidelines, standards and references:

- PED 97/23/EC, strength calculation according to ASME B31.8, class 2
- ATEX directive 94/9/EC, type approval Ex II 2 G c IIC T6
- MID according to 2004/22/EC, Type approval T10119
- Pattern evaluation report CVN-607412-01, according to European standard EN 12261:2002/A1:2006
- Pattern evaluation report CVN-607412-02 according to international metrological standard OIML R 137-1:2006

All manufactured meters are tested on official PTB or NMI approved test facilities.

## Main features

- Improved pressure drop behaviour
- Increased flow capacity per size
- Flow range 32 - 40000 m<sup>3</sup>/h
- Diameters DN 200 - 600 (8" - 24")
- Pressure rates  
PN 10 - 63 and ANSI class 150 - 600 (further pressure rates on request)
- Temperature range -25 °C to +70 °C
- Housing length 3 DN
- Low carbon steel housing
- Integrated HF-pulsar
- Automatic lubrication system  $\geq$  DN400
- MID according to 2004/22/EC
- Media: natural gas (other gases on request)
- IP54 vented index

## Options

- Bi-directional measurement
- Automatic lubrication system  $\leq$  DN300
- Single encoder MI-II
- IP67 non-vented index

# SM-RI-2: Turbine gas meters for custody transfer

## Multi-Index II

A rugged and vented metal index with protection class IP54  
 Standard fitted with an external Reed switch IN-S11 (Binder plug) including a protection against tampering. Double index standard for Bi-directional version.

### Options

- Double MF sensor (separate Binder plug)
- Mechanical drive 25H7 acc. EN 12261, protection class IP54
- Non-vented version with protection class IP67 (in combination with moisture absorption filter)



Multi-index 2 without mechanical drive



Multi-index 2 with mechanical drive

## Accuracy, metrology

The SM-RI-2 turbine gas meters in their metrological behaviour conform to the specifications of international standards for turbine gas meters.

Typical error limits according to OIML R137-1:2006 (class 1) and MID 2004/22/EC (class 1):

- $\pm 2.0\%$  for  $Q_{min}$  to  $Q_t$
- $\pm 1.0\%$  for  $Q_t$  to  $Q_{max}$

Smaller limits on request

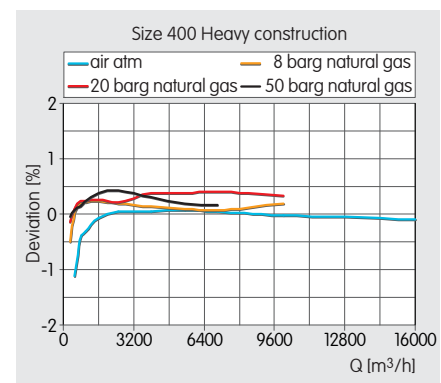
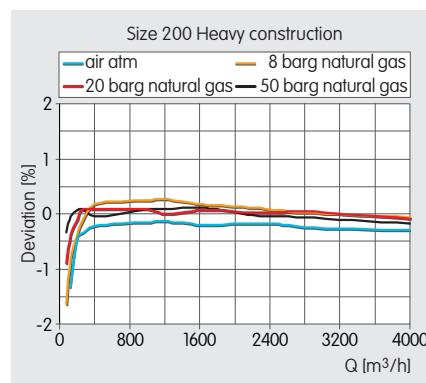
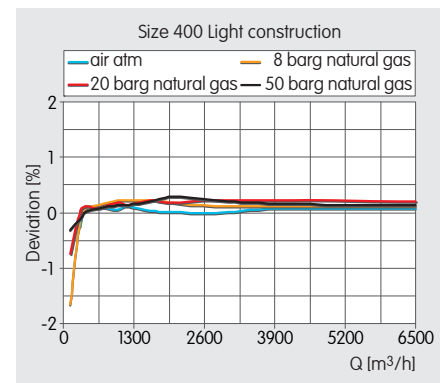
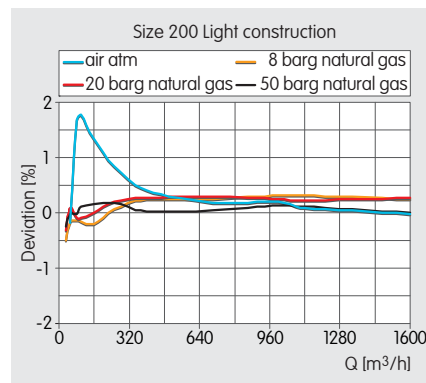

## Pressure drop

The average pressure drop of the SM-RI-2 turbine meter using atmospheric natural gas with a density of 0.8 is measured at 1 x DN upstream to 1 x DN downstream of the meter on a straight pipe of the same size as the meter. Individual pressure drop values are given in the overview (page 3).

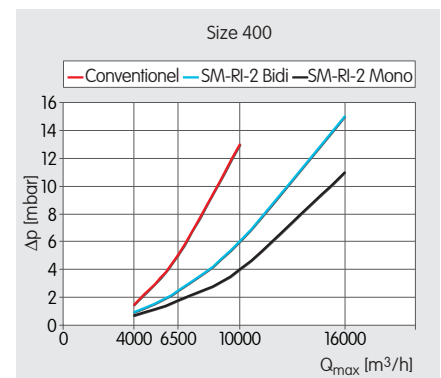
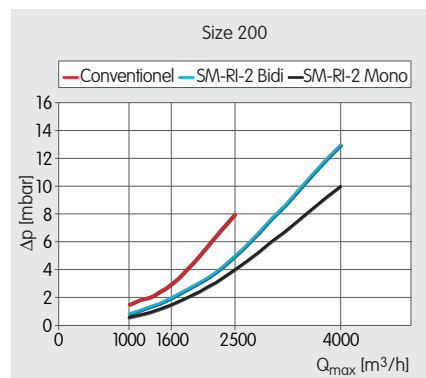

## Typical characteristics of measurement errors

Each SM-RI-2 meter is tested with atmospheric air to traceable calibrated references. Optionally, meters can be high pressure calibrated with air or natural gas on test facilities traceable to primary international standards.

### Note

1. Please note that the test facilities can meet the required test pressure, and measuring range for the concerning meter type and dimensions.
2.  $Q_{min}$  at different measuring ranges

$Q_{max}$	$Q_{min}$		
	1:20	1:30	1:50
1000	50	32	20
1600	80	50	32
2500	130	80	50
4000	200	130	80
6500	320	200	130
10000	500	320	200
16000	800	500	320
25000	1300	800	500
40000	2000	1300	800

3. Please note that there are different  $Q_t$  (transition points)

Rangeability	$Q_t/Q_{max}$
1:20	0,20
1:30	0,15
1:50	0,10

4. Required inlet pipe length  $L \geq 5$  DN

High pressure measuring range							
Diameter	Bearing Construction Light / Heavy	$Q_{max}$	Measuring range			Operating conditions	
			1:20 Min. working pressure (g)	1:30	1:50	$P_{max}^{**}$	$\rho_{max}$
DN200 8"	L	1000	atm	4	16*	120	100
	L	1600	atm	atm	4	65	53
	L	2500	atm	atm	atm	21	17
	L	4000	atm	atm	atm	4	4
	H	1600	4	16*	50*	120	100
	H	2500	atm	4	16*	120	100
	H	4000	atm	atm	4	65	53
DN250 10"	L	1600	atm	4	16*	120	100
	L	2500	atm	atm	4	65	53
	L	4000	atm	atm	atm	21	17
	L	6500	atm	atm	atm	4	4
	H	2500	4	16*	50*	120	100
	H	4000	atm	4	16*	120	100
	H	6500	atm	atm	4	65	53
DN300 12"	L	2500	atm	4	16*	120	100
	L	4000	atm	atm	4	65	53
	L	6500	atm	atm	atm	21	17
	L	10000	atm	atm	atm	4	4
	H	4000	4	16*	50*	120	100
	H	6500	atm	4	4	120	100
	H	10000	atm	atm	4	65	53
DN400 16"	L	4000	4	4	16*	120	100
	L	6500	atm	4	4	65	53
	L	10000	atm	atm	4	21	17
	L	16000	atm	atm	atm	4	4
	H	6500	4	16*	50*	120	100
	H	10000	atm	4	16*	65	53
	H	16000	atm	atm	4	21	17
DN500 20"	L	6500	4	16*	50*	120	100
	L	10000	atm	4	16*	65	53
	L	16000	atm	atm	4	21	17
	L	25000	atm	atm	atm	4	4
	H	10000	4	16*	50*	120	100
	H	16000	atm	4	16*	65	53
	H	25000	atm	atm	4	21	17
DN600 24"	L	10000	atm	4	16*	120	100
	L	16000	atm	atm	4	65	53
	L	25000	atm	atm	atm	21	17
	L	40000	atm	atm	atm	4	4
	H	16000	4	16*	50*	120	100
	H	25000	atm	4	16*	65	53
	H	40000	atm	atm	4	21	17

\* These conditions are not mentioned in the type approval but can be performed as an additional measuring point  
 \*\*Maximum operating pressure for natural gas conditions  $\rho = 0.8$  [kg/m<sup>3</sup>]

## Pulse data / Pressure drop data

The meter can be provided with low (LF), middle (MF) and/or high frequency (HF) impulse outputs, at which the appertaining impulse value is stated on the meter. For the different meter sizes the frequency impulse values are stated in the overview.

Diameter	$Q_{max}$	Pressure drop		Pulse data				
		Mono [mbar]*	Bidi [mbar]*	LF Index [Imp/m <sup>3</sup> ]	MF Index [Imp/m <sup>3</sup> ]	HF Rotor [Imp/m <sup>3</sup> ]	MF Index [Hz at $Q_{max}$ ]	HF Rotor [Hz at $Q_{max}$ ]
DN200 8"	1000	0.6	0.8	1	208	1335	58	371
	1600	1.5	2.0	0.1	92	1335	41	593
	2500	3.7	5.0	0.1	92	1335	64	927
	4000	9.5	12.8	0.1	92	1335	102	1483
DN250 10"	1600	0.6	0.8	0.1	48	690	21	307
	2500	1.5	2.0	0.1	48	690	33	479
	4000	3.8	5.1	0.1	48	690	53	767
	6500	9.9	13.4	0.1	48	690	87	1246
DN300 12"	2500	0.7	0.9	0.1	64	406	44	282
	4000	1.8	2.4	0.1	64	406	71	451
	6500	4.7	6.4	0.1	64	406	116	733
	10000	11.2	15.2	0.1	64	406	178	1128
DN400 16"	4000	0.7	0.9	0.1	33	207	37	230
	6500	1.8	2.4	0.1	33	207	60	374
	10000	4.2	5.7	0.1	33	207	92	575
	16000	10.8	14.5	0.01	14.5	207	64	920
DN500 20"	6500	0.7	0.9	0.1	16.5	107	30	193
	10000	1.6	2.2	0.1	16.5	107	46	297
	16000	4.2	5.6	0.01	7.5	107	33	476
	25000	10.1	13.7	0.01	7.5	107	52	743
DN600 24"	10000	0.7	1.0	0.1	9.5	61	26	169
	16000	1.9	2.5	0.01	9.5	61	42	271
	25000	4.6	6.1	0.01	4.2	61	29	424
	40000	11.7	15.7	0.01	4.2	61	47	678

\* at  $Q_{max}$  natural gas = 0.8 kg/m<sup>3</sup>

# SM-RI-2: Turbine gas meters for custody transfer

## Dimensions and weights

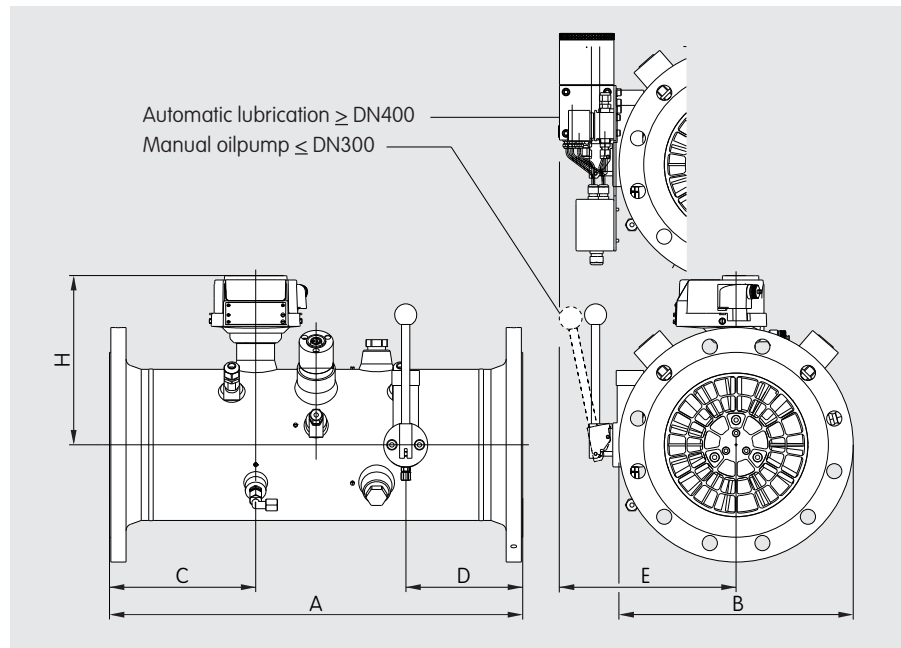

Size [mm]	Dimensions						Pressure rate [ANSI class]	Weight [kg]
	A	B	C	D	E	H		
200 (8")	600	As per flange class dimension	212	192	256	245	150 / 300 / 600	82 / 106 / 140
250 (10")	750		287	245	283	272	150 / 300 / 600	98 / 134 / 213
300 (12")	900		337	285	308	297	150 / 300 / 600	145 / 190 / 270
400 (16")	1200		487	435	350	338	150 / 300 / 600	360 / 420 / 530
500 (20")	1500		637	585	400	390	150 / 300 / 600	600 / 730 / 900
600 (24")	1800		787	735	452	440	150 / 300 / 600	980 / 1180 / 1385

### Standard SM-RI-2 configuration\*

Material/configuration	<ul style="list-style-type: none"> <li>- Pipe material: ASTM A333 Grade 6</li> <li>- Flange material: ASTM A350 Grade LF2</li> <li>- Flange rating: ASME B16.5 Class150 (i.e. ANSI150)</li> <li>- Flange treatment: RF Smooth finish</li> <li>- Flow Straightener X4X: Metal</li> <li>- Index: Vented MI-2 Mono (double index for bi-directional version)</li> <li>- LF: 2x LF pulser within one IN-S11 Binder plug</li> <li>- HF: 1x HF pulser with Binder plug (2 x HF pulser for bi-directional version)</li> <li>- Lubrication: Manual Oilpump for <math>\leq</math> DN300 Automatic lubrication system <math>\geq</math> DN400</li> <li>- Pressure port: 1 x Pm plus 1xP (Swagelok 6 mm)</li> <li>- Painting: RAL 1004</li> </ul>
Documentation/ certificates	<ul style="list-style-type: none"> <li>- Instruction Manual / Lubrication + Safety Instruction</li> <li>- Electrical connection scheme</li> <li>- Factory calibration certificate (at low pressure)</li> <li>- Declaration of conformity in accordance with PED-97/23/EC and ATEX-94/9/EC</li> <li>- Inspection certificate EN 10204-3.1 in accordance with PED-97/23/EC</li> </ul>
Packaging	- Wooden crate
Others	- Measuring range: 1:20 acc. MID (Type approval T10119)

\* Extensions to the standard will cost extra charges and might result in extended delivery-times

## Your contacts

Germany  
Elster GmbH  
Steinern Str. 19 - 21  
55252 Mainz-Kastel  
T +49 6134 605 0  
F +49 6134 605 223  
www.elster-instromet.com  
info@elster-instromet.com

Belgium  
Elster-Instromet N.V.  
Rijkmakerlaan 9  
2910 Essen  
T +32 3 670 0700  
F +32 3 667 6940  
www.elster-instromet.com  
info@elster-instromet.com

Singapore  
Elster-Instromet Sdn. Bhd. (Singapore Branch)  
160 Paya Lebar Road  
#04-01 Orion@Paya Lebar  
Singapore 409022  
T +65 6247 7728  
F +65 6247 7729  
sales@elster-instromet.com.sg

SM RI 2 EN02

A24.07.2009